



NuCraft Metal Products  
402 Southline Road  
Roscommon, MI 48653  
(989) 275-8054

[www.craftlander.com](http://www.craftlander.com)

## Over-Center<sup>™</sup> Hydraulic Aluminum Lift

4000 lbs Capacity    Model # H40108, H40120



- ASSEMBLY
- INSTALLATION
- REPLACEMENT PARTS

**READ complete manual CAREFULLY  
BEFORE attempting operation**

# INTRODUCTION

Thank you for purchasing a Craftlander Boat Hoist. We feel you have made a wise choice and hope that you are completely satisfied with the performance of your lift.

Please take a moment and read through the entire instruction manual before beginning assembly. Make sure that all pieces are assembled in the proper sequence or complications may result.

Be certain you know exactly what's going to happen during each step. There are movable parts and therefore we emphasize CAUTION should be exercised to ensure your safety at all times.

For best results the hoist must be assembled on a reasonably level spot. We recommend that you hire a professional or have help when assembling your hoist.

# GENERAL INFORMATION

Unless otherwise specified, stainless steel hex head bolts and hardware are used throughout assembly. Make sure to lubricate the threads of all eight forward and aft H-frame pivot bolts with the anti-seize compound to prevent galling and jamming of the nuts during assembly.

Whenever the terms "LEFT" and "RIGHT" are used in this manual they are referring to the orientation of the boatlift when viewed from the aft end facing forward. This is the end that the boat enters the hoist.

When placing a parts order, refer to this manual for proper part numbers and place order using both PART NO. and DESCRIPTION.

\*\*Make sure that you do not overload your boatlift. Empty all water ballast and bilge water prior to using your boatlift. Prevent rain water from accumulating in your boat while stored on the lift. See page ten for additional loading and operational instructions.

# TABLE OF CONTENTS

Adjustable Leg & Foot Pad Assembly.....	Page 3
Side Rail Assembly.....	Page 4
Foward & Aft H Frame Assembly.....	Page 5
Bunk Rail Assembly.....	Page 6
Bunk Board Assembly.....	Page 7
Hydraulic Cylinder Assembly.....	Page 8
Power Package Assembly.....	Page 9
Installation Instructions.....	Page 10
First Use Adjustments.....	Page 10
Periodic Maintenance.....	Page 10
Operating Instructions.....	Page 10
Optional Centering Device Assembly.....	Page 11
Optional Lower Unit Stop Assembly.....	Page 12
Trouble Shooting Questions & FAQ.....	Page 13
Warranty.....	Page 14

# ADJUSTABLE LEG AND FOOT PAD ASSEMBLY

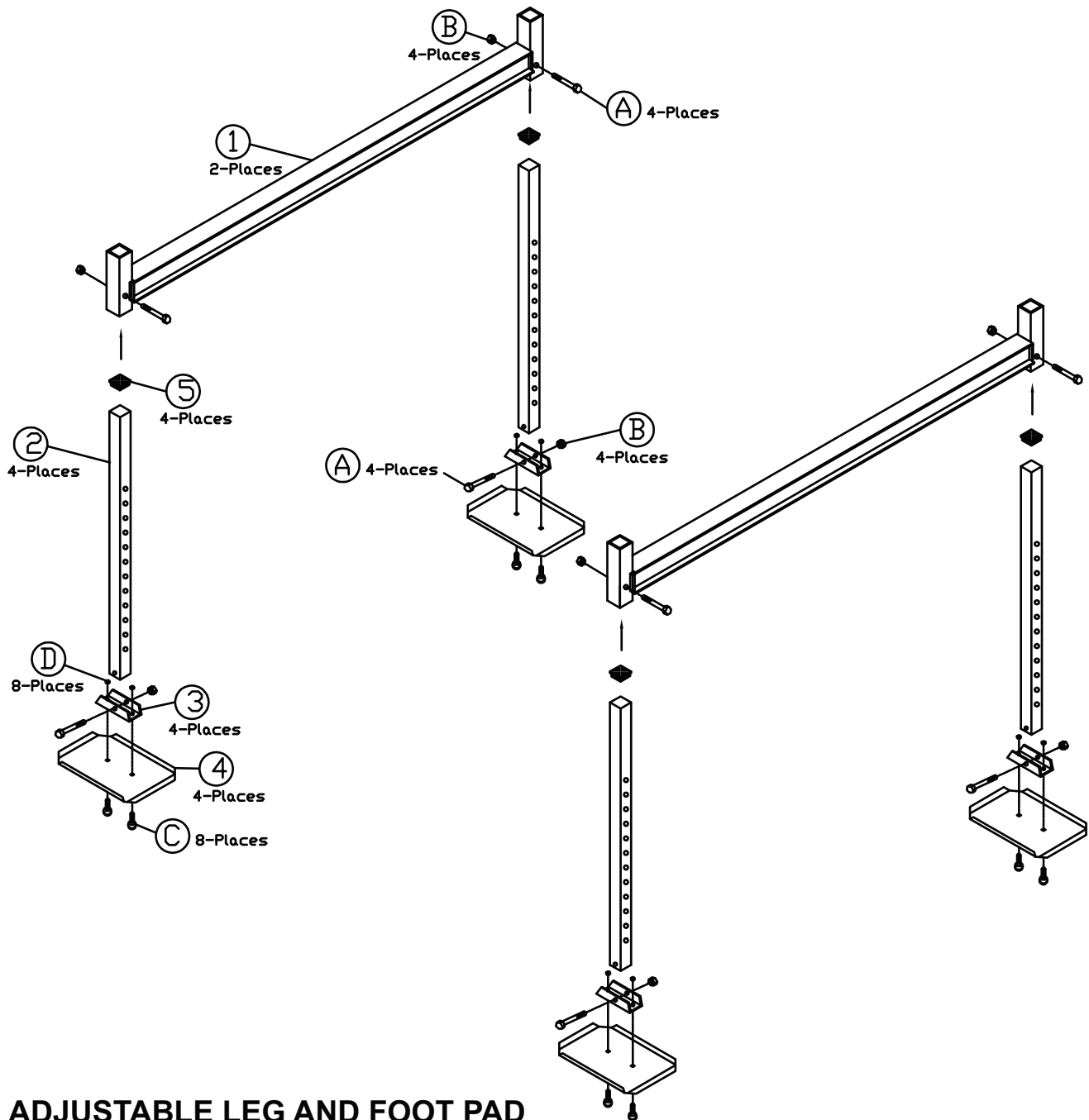

## ADJUSTABLE LEG AND FOOT PAD ASSEMBLY INSTRUCTIONS

1. Fasten foot pad bracket (3) to foot pad (4) with 2-3/8 x 3/4 carriage bolts (C) and 3/8 serrated nuts (D) next fasten leg (2) to foot pad bracket (3) with 7/16 x 3 1/2 bolt (A) and 7/16 nut (B).
2. Insert the adjustable legs into the front and rear lower 5 1/2" twin beam spreaders (1) fasten with 7/16 x 3 1/2 bolt (A) and 7/16 nut (B).

Please order replacement parts by  
PART NO. and DESCRIPTION.

REF	QTY	DESCRIPTION	PART #
A	4	7/16" X 3 1/2 SS BOLT	H-B433500-SS
B	4	7/16" SS NUT	H-N43-SS
C	8	3/8 X 3/4 SS CARRIAGE BOLT	H-BC37075-SS
D	8	3/8" SERRATED NUT	H-N37-SS
1	2	LOWER 5 1/2" TWIN BEAM SPREADER	MH-H-40108LS, OR MH-H-40114LS, OR MH-H-40120LS
2	4	2 1/2" SQ. X 54" LEG	MH-VLT54
3	4	FOOT PAD LEG BRACKET	MH-VLB
4	4	FOOT PAD	MH-VFP
5	4	2 1/2" PLASTIC LEG CAP	H-PCS250

# SIDE RAIL ASSEMBLY

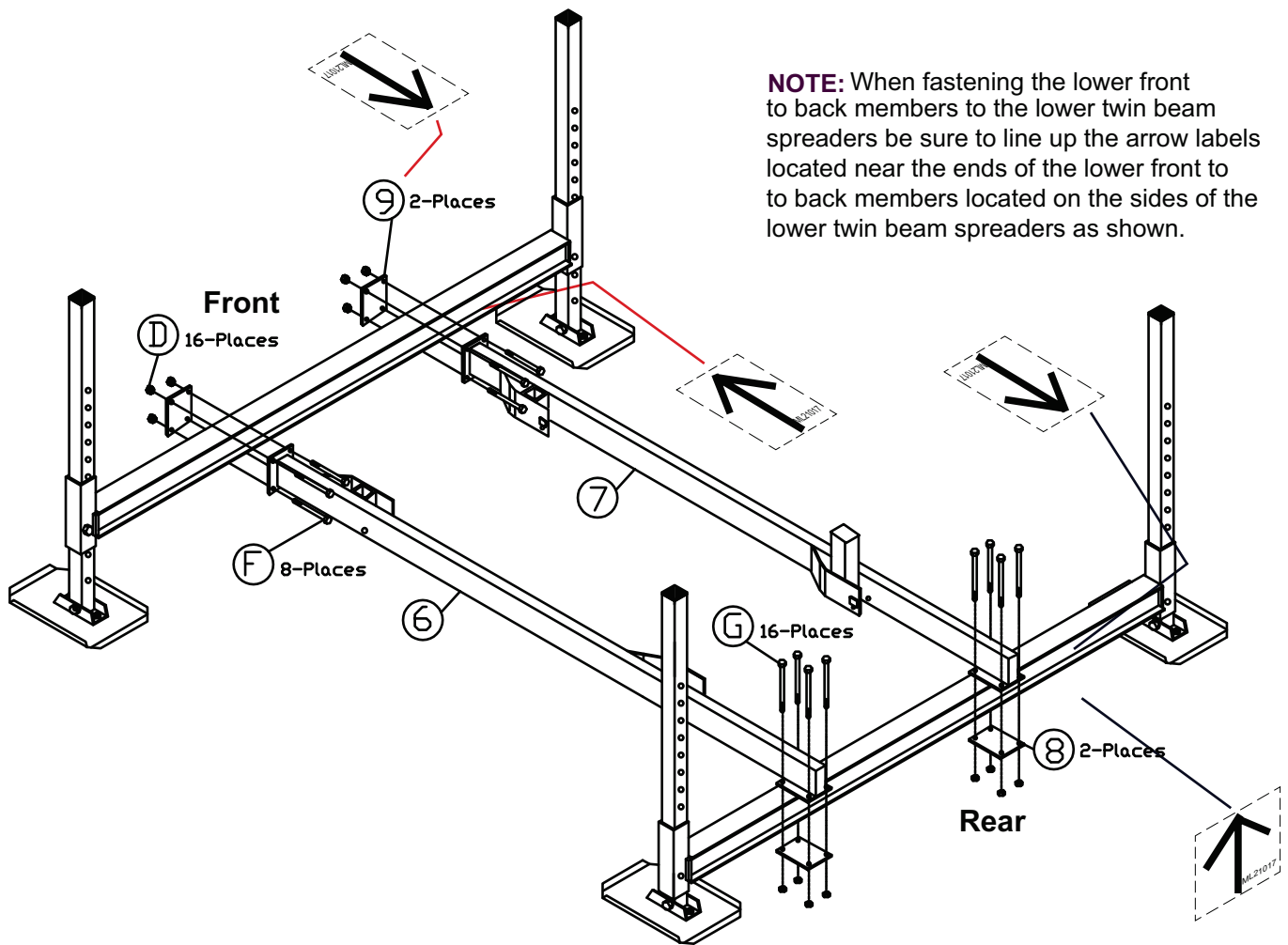

**NOTE:** When fastening the lower front to back members to the lower twin beam spreaders be sure to line up the arrow labels located near the ends of the lower front to back members located on the sides of the lower twin beam spreaders as shown.

## SIDE RAIL ASSEMBLY INSTRUCTIONS

1. Fasten the right(7) and left(6) lower front to back member with in the front 1/4 x 5 3/4 square backer plate (9), 3/8 x 5 bolts(F) and 3/8 serrated nuts(D). Use the arrows to locate the front to back members on the twin beam spreaders. Keep bolts loose until the stands are in place.
2. Do the same on the rear with 1/4 x 5 x 7 1/4 backer plates(8), 3/8 x 6 1/2 bolts(G) and 3/8" serrated nuts(D). Use the arrows to locate the front to back members on the twin beam spreaders. Keep bolts loose until the stands are in place

Please order replacement parts by  
PART NO. and DESCRIPTION.

REF	QTY	DESCRIPTION	PART #
D	16	3/8" SERRATED NUT	H-N37-SS
F	8	3/8" X 5" SS BOLT	H-B37500-SS
G	16	3/8" X 6 1/2" SS BOLT	H-B37650-SS
6	1	LEFT HAND LOWER FRONT TO BACK MEMBER	MH-H-40LL
7	1	RIGHT HAND LOWER FRONT TO BACK MEMBER	MH-H-40LR
8	2	1/4" BACKER PLATE FRONT 5 3/4" SQ.	MH-H-40FBP
9	2	1/4" BACKER PLATE REAR 5" X 7 1/4"	MH-H-40RBP

# FRONT & REAR H-FRAME ASSEMBLY

**NOTE:** The lift is shown in the raised position for clarification of component parts and their related positions. The H stands will pivot toward the rear and the remainder of the lift will be assembled in the lowered position.

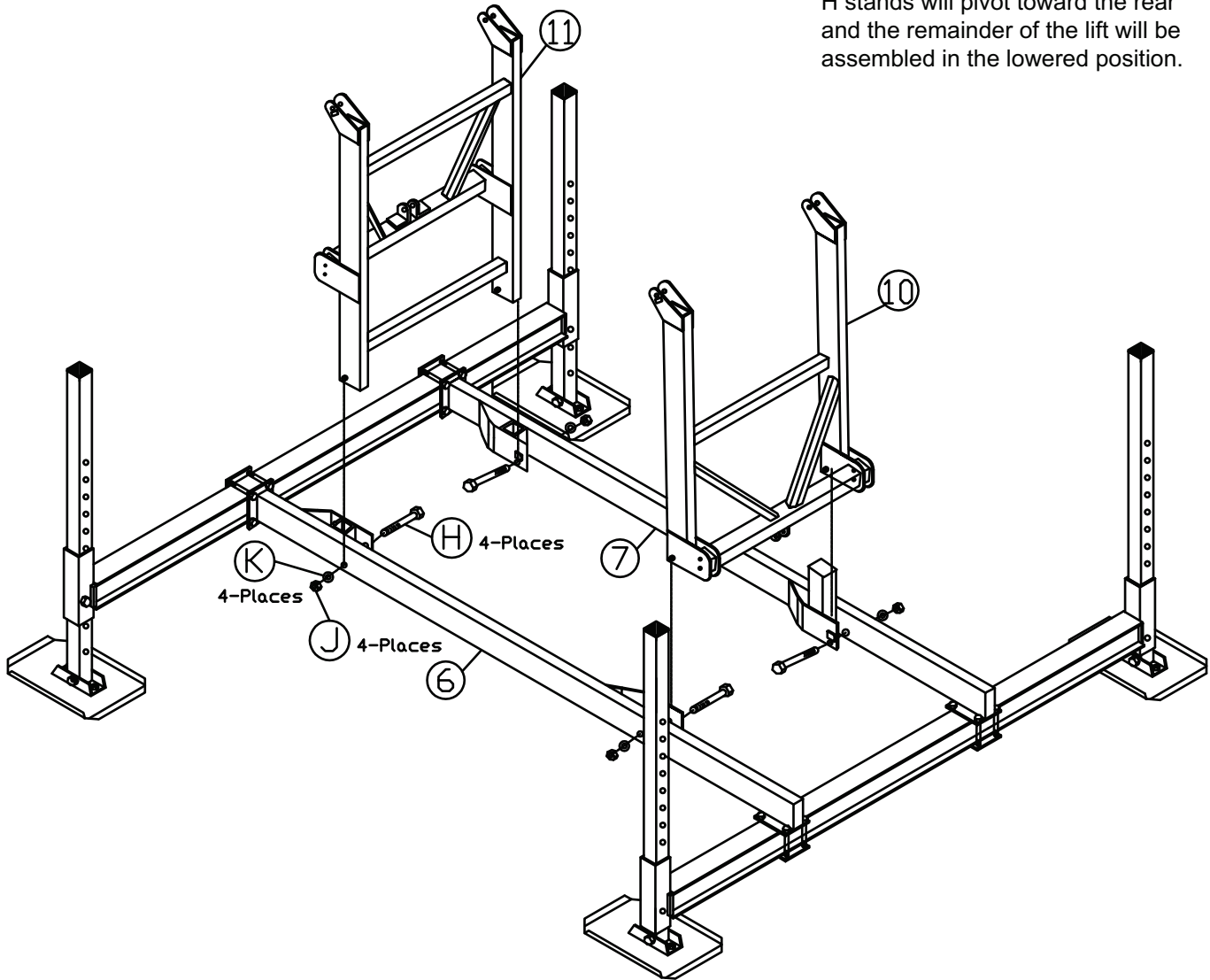

## ASSEMBLY INSTRUCTIONS

1. Attach the front H stand (11) to the lower front to back members (6) & (7) with 3/4 x 6 1/2 bolts (H) and 3/4 lock nuts (J). Do the same with the rear H stand (10).

**Note:** These bolts are directional and must be installed to the middle of the lift toward the outside. This will require anti seize. To prevent galling and jamming of the nuts.

2. Finish tightening the 3/8 bolts that hold the backer plates to the lower front to back members on the lower twin beam spreaders.

Please order replacement parts by  
PART NO. and DESCRIPTION.

REF	QTY	DESCRIPTION	PART #
H	4	3/4" X 6 1/2" SS BOLT	H-B75650-SS
J	4	3/4" NYLON INSERT SS LOCK NUT	H-NL75-SS
K	4	3/4" SS WASHER	H-W75-SS
10	1	4000 H STAND REAR	MH-H-40SR
11	1	4000 H STAND FRONT	MH-H-40SF

# BUNK RAIL ASSEMBLY

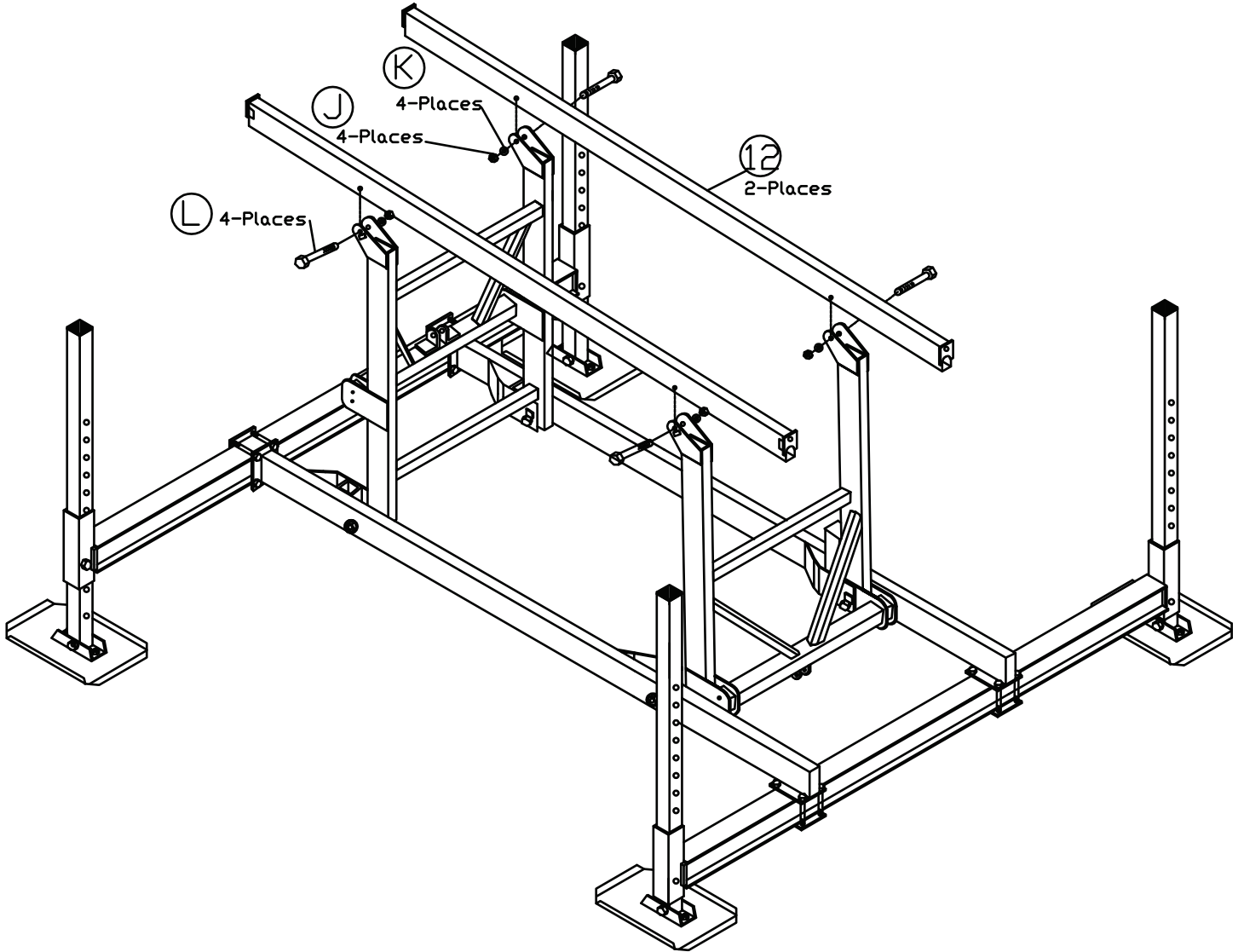

## ASSEMBLY INSTRUCTIONS

1. Attach bunk rail support (#12) using four 3/4" x 4-1/2" hex head bolts SS (L), four 3/4" flat washers SS (K), and four 3/4" nylon insert lock nuts SS (J).

**NOTE:** These bolts are directional and must be installed from the outside of the lift toward the middle. They will require anti-seize compound on the threads to prevent galling and jamming of the nuts.

Please order replacement parts by  
PART NO. and DESCRIPTION.

REF	QTY	DESCRIPTION	PART #
J	4	3/4" NYLON INSERT SS LOCK NUT	H-NL75-SS
K	4	3/4" SS WASHER	H-W75-SS
L	4	3/4" X 4 1/2" SS BOLT	H-B75450
12	2	4000 BUNK RAIL SUPPORT	MH-H-40BR



# BUNK BOARD ASSEMBLY

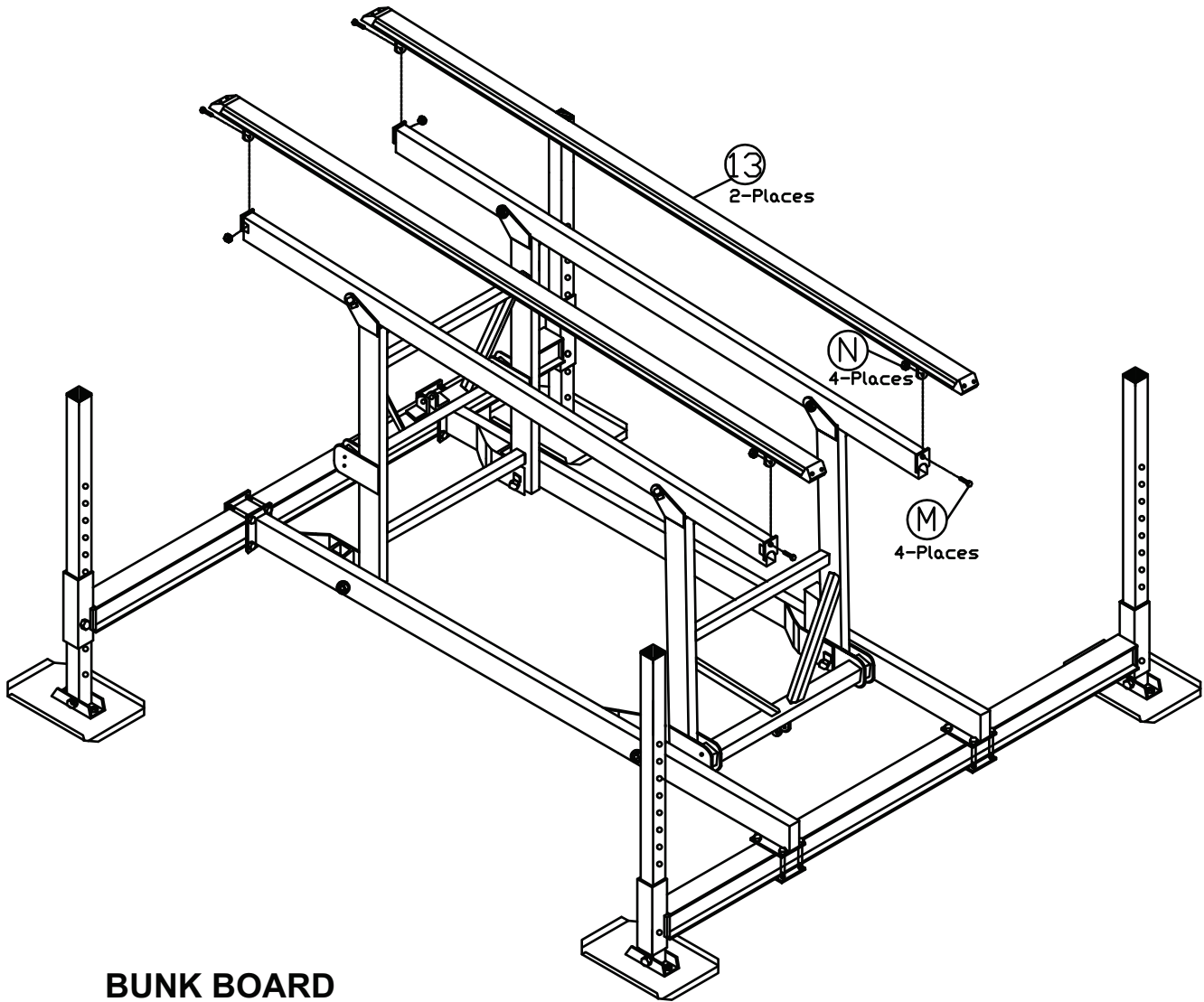

## BUNK BOARD ASSEMBLY INSTRUCTIONS

1. The Vinyl Bunk Assembly (#13) comes pre-assembled with the vinyl bunk angle brackets. Attach the vinyl bunk assemblies (#13) to the bunk rails using two 3/8" x 1-1/4" hex head bolts SS (M), and four 3/8" nylon insert lock nuts (N).

Please order replacement parts by  
PART NO. and DESCRIPTION.

REF	QTY	DESCRIPTION	PART #
M	4	3/8" X 1 1/2" BOLT	H-B50150-SS
N	4	3/8" NYLON INSERT SS LOCK NUT	H-NL50-SS
13	2	VINYL BUNK ASSEMBLY	MH-VBV35-45-NH

# HYDRAULIC CYLINDER ASSEMBLY

**NOTE:** The lift is shown in the raised position for clarification of component parts and their related positions. The lift **MUST** be in the lowered position during hydraulic component installation.

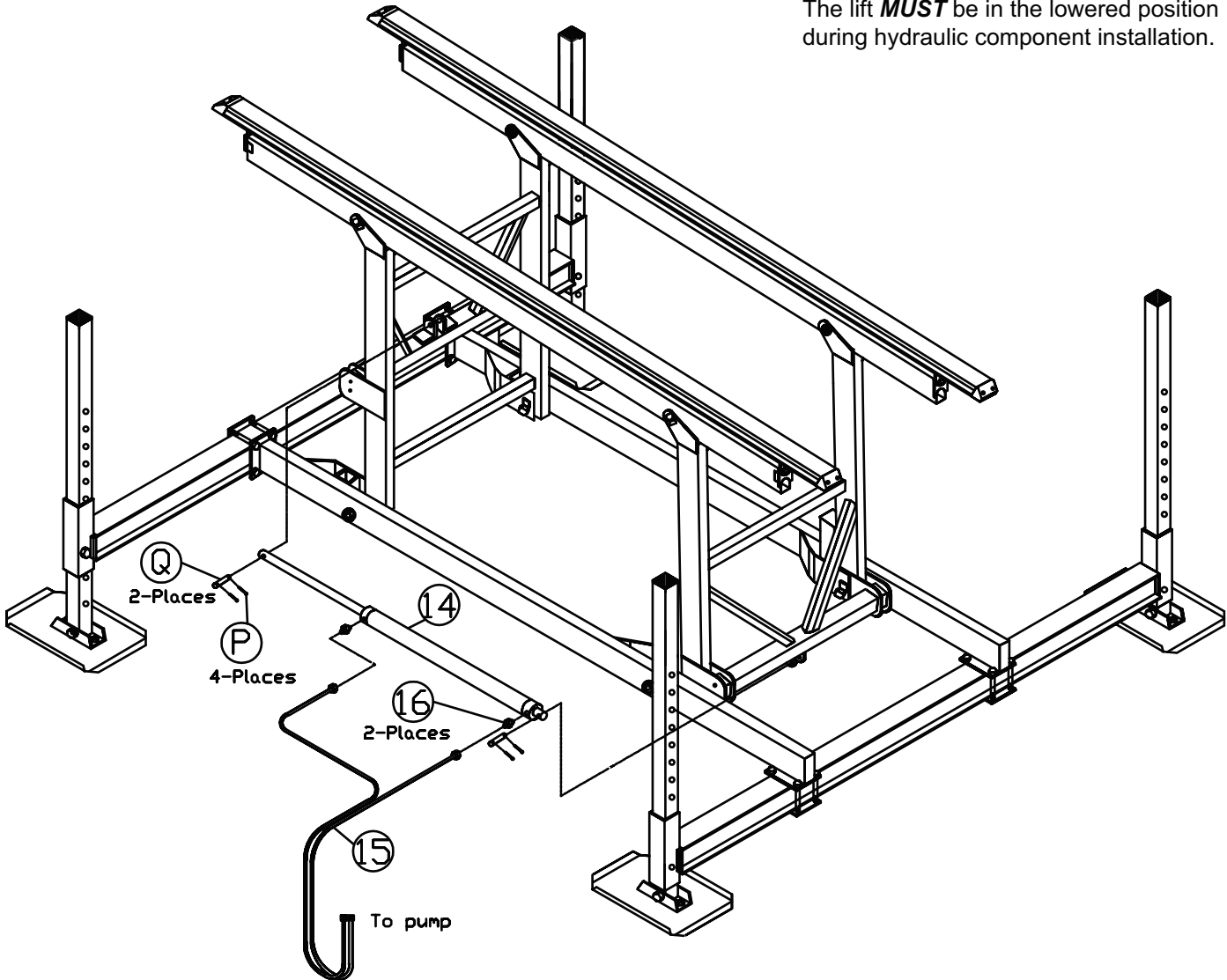

Please order replacement parts by  
PART NO. and DESCRIPTION.

## HYDRAULIC CYLINDER ASSEMBLY INSTRUCTIONS

1. Mount the cylinder using two 3/4" x 3-1/2" cylinder mounting pins SS (Q) and four cotter pins SS (P).

**NOTE:** Be sure to position the cylinder with the hoses at rear of lift, facing the side that the pump will be on.

REF	QTY	DESCRIPTION	PART #
P	4	1/8 X 1 1/2 SS COTTER PIN	H-CP1215
Q	2	3/4" SS PIN	H-PIN75375
14	1	3" BORE ALUMINUM CYLINDER	MH-H-D12149
15	1	1/4" X 216" TWIN HYDRAULIC HOSE	MH-H-D11150
16	2	MALE HYDRAULIC FITTING	MH-H-D11141



# POWER PACKAGE ASSEMBLY

Power Box and Solar Panel

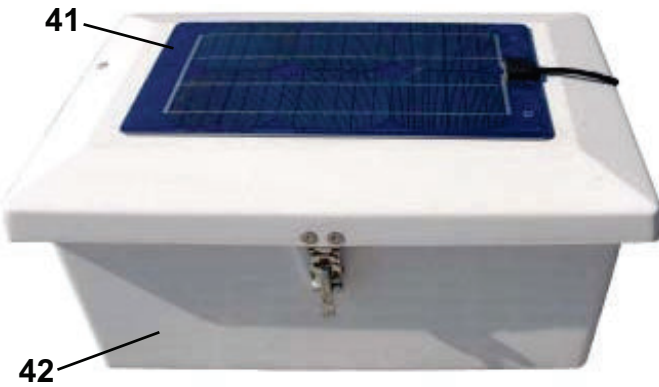

Power Unit Assembly

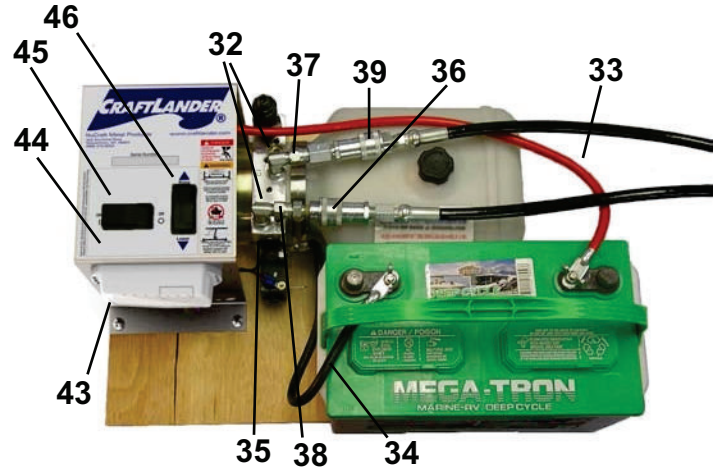

Remote Control Receiver

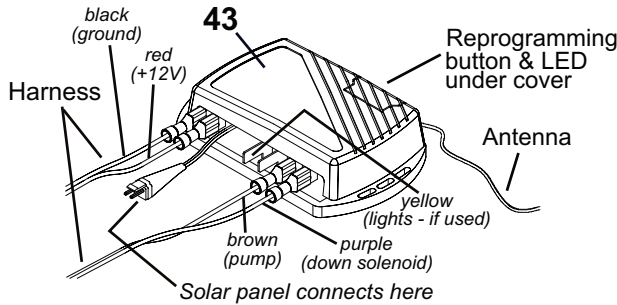

Remote Key Fobs



Hydraulic Fluid



## POWER UNIT ASSEMBLY

1. The Hydraulic Pump will arrive fully assembled. Make sure all the connections are snug to prevent leaks or loss of power to the unit.
2. Install a Group 27 Marine Grade Battery as shown above. Be sure to connect the Red Battery Cable (#33) to the positive terminal and the Black Battery Cable (#34) to the negative terminal.

NOTE: Ensure battery cables are correctly connected and their terminals are tight (use pliers).

3. Slide the Hydraulic Cylinder Hoses (#30) through the access hole in the side of the White Fiberglass Box (#42) and attach them to their corresponding Quick Couplers (#36, #39).

NOTE: Ensure the Quick Couplers are completely seated with no gaps at the connection joint.

4. Pass the cable from the Solar Panel through the same access hole as the hoses and plug it into the Remote Control Unit as indicated in the diagram above.

5. Test the lift on dry ground using the Up/Down Switch (#46) and the Key Fob Transmitters (#47). Inspect the system for leaks.
6. Disconnect the Hydraulic Cylinder Hose Quick Couplers to separate the Power Unit Assembly from the Lift.

NOTE: Before disconnecting the Hydraulic Cylinder Hose Assemblies, lower the lift completely, then raise slightly.

REF. NO.	PART NO.	QTY.	DESCRIPTION
32.	BMPU853-6-6	2	90 Degree male Hyd. Fitting
33.	BMPUPBC	1	24" Red #4 Battery Cable
34.	BMPUNBC	1	12" Black #4 Battery Cable
35.	BMPUPF	1	12 Volt DC Hyd. Pump w/ wiring
36.	BMPUB30-4	1	Male Quick Coupler
37.	BMPU6G6X-S	2	Straight Hyd. Fitting female to male
38.	BMPU0106-4-6	2	Straight Hyd. Fitting male to female
39.	BMPUP30-4	1	Female Quick Coupler
40.	BMHYDFL	1	Hydraulic Fluid (Quart)
41.	BMPUSPA	1	Solar Panel Assy
42.	BMPUWB	1	White Fiberglass Box w/Locking Lid
43.	BMPURC	1	Remote Control Unit
44.	BMPUCP	1	Control Panel
45.	BMPUOO	1	On/Off Switch
46.	BMPUUD	1	Up/Down Switch
47.	BMPUKEYFOB	2	Key Fob Transmitter

Please order replacement parts by  
PART NO. and DESCRIPTION.

**We recommend that you have your lift installed by a professional lift service. If one is not available, we recommend that you have help when installing your lift following these instructions. If you have problems or questions feel free to call NuCraft for assistance.**

## INSTALLATION INSTRUCTIONS

1. Begin by measuring the approximate depth of the water where your hoist is to be placed. Make sure you have enough water depth to float the boat onto the hoist. Set the adjustable legs accordingly at the water's edge. See page 11.
2. Place the hoist into position in the water. Make sure the hoist is level from side to side and front to rear.
3. When the hoist is in position, connect the Hydraulic Cylinder Hoses to the Power Unit.

NOTE: See first use and adjustments.

4. Lower the cradle of the hoist into the water just enough to allow the boat to float over the bunk boards. Guide the boat onto the bunk boards and position the fore and aft center of gravity in the middle of the bunk boards.
5. Raise the cradle far enough so the boat just starts to lift. Remove boat from lift. Tighten bunk board pivot bolts.
6. After making sure no damage will result to either the boat or the hoist, lift the boat from the water.

NOTE: See first use and adjustments.

7. To remove your boat from the hoist, lower the cradle only as far as necessary to release the boat. Then idle off in reverse.

## PERIODIC MAINTENANCE

1. Lifts installed in brackish or salt water should be tested with sacrificial zinc anodes and inspected monthly.
2. Verify that the lift frame is level monthly.
3. Check battery terminals for corrosion quarterly.
4. Tighten all bolts annually.
5. Inspect the hydraulic hoses, hydraulic fittings and cylinders every 6 months and replace as needed.
6. Check the hydraulic fluid in the reservoir with the lift in the fully lowered position. If fluid is needed, use Craftlander hydraulic fluid (#D-08159). Change the hydraulic fluid every two years.

## FIRST USE ADJUSTMENTS

1. Position the boat over the lift to the following specifications: If your boat is an outboard, inboard/outboard, or V-drive, the transom should be 2 inches off the end of the bunk boards. If your boat is a mid-engine or a shaft-drive, the transom should be 12 to 24 inches off the end of the bunk boards.
2. Raise the boat slowly. If more than 2 inches of settling occurs, stop, carefully lower the lift to remove the boat and re-level the boat lift. Continue repeating this step until the boat can be raised into the full Over-Center™ position without settling.
3. Remove the boat. Verify that the lift frame is level. Re-level the frame if necessary.
4. The loaded lift should raise and lower smoothly at the same relative speed.

**NOTE:** If you purchase a new boat, be sure it is within the weight capacity limits of the lift. Also remember that these adjustments will have to be done again to accommodate the new boat.

**Maximum lifting capacity is 5000 pounds  
DO NOT OVERLOAD!**

## OPERATING INSTRUCTIONS

1. To operate the Power Unit manually open the Power Box (#42), turn on the On/Off Switch (#45) and use the Up/Down Switch (#46). To operate the lift remotely, turn the On/Off Switch to ON and use a Key Fob Transmitter (#47).
2. To remove your boat from the hoist, lower the cradle as far as necessary to release the boat. Then idle off in reverse.
3. When entering the hoist, approach slowly and stay between the Centering Guides (optional) until the boat comes to rest against the Lower Unit Stop (optional) or is positioned as noted in *First Use Adjustments* (step 1). Disembark all people and animals from the boat. Then proceed to raise the boat lift.
4. Raise the lift to the complete OverCenter™ position and secure the boat.
5. Turn the On/Off Switch to OFF and lock the Power Box. This will reduce the opportunity of theft and help prevent water from entering the box.

# TROUBLE SHOOTING QUESTIONS AND FAQ

## Q: THE BATTERY WILL NOT HOLD A CHARGE

- A: Verify that the loaded boat is not exceeding the weight capacity of the lift.
- A: Ensure the solar panel is properly connected.
- A: Re-align the solar panel for proper exposure to the sun.
- A: Recharge the battery with a 10 amp charger and check the charge again.
- A: Have the battery tested. It may be old and require replacement.
- A: If the lift is being used frequently during the day, it may be necessary to use a 110-volt maintainer/charger.

## Q: THE REMOTE CONTROL IS NOT FUNCTIONING PROPERLY

- A: Verify that the red LED on each remote control key fob comes on when each button is pushed. If the LED is not bright, the remote's range is reduced - replace the fob's battery.
- A: Verify that the large power unit battery is charged and connections are tight.
- A: Make sure the antenna wire on the power unit's remote receiver is located properly.
- A: Reprogram the remote key fobs.

## Q: THE HAND HELD REMOTE KEY FOBS NEED TO BE REPROGRAMMED

1. Turn on the power switch located on the top of the control panel.
2. Locate the small red button under the cover of the white remote control receiver located inside the pump box. This is the reprogramming button.

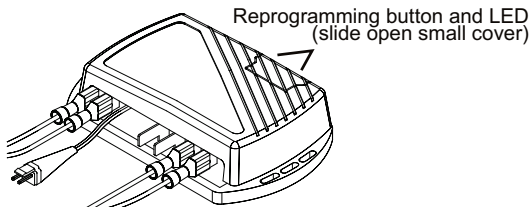

3. Push the reprogramming button until the red LED next to the button turns on. Release the button.
4. Press the UP button on one key fob until the LED goes out. Release the button.
5. Press the fob's UP button again. The LED should flash slowly. Release the button.
6. Repeat steps 3-5 for your other fob.
7. Test all key fobs by individually pressing first the UP button, pausing, and then the DOWN button. Verify the lift direction visually.

## Q: THE PUMP DOESN'T RUN

- A: Check the battery charge, recharge if necessary.
- A: Check the battery connections, clean and re-secure if necessary.

## Q: THE PUMP RUNS, BUT THE LIFT DOESN'T MOVE

- A: Check the 'quick couplers' in the Power Unit. If they are not screwed together tight enough, built-in check valves will not allow fluid to flow. See Page 9.
- A: Check the fluid level. See Page 9.

## Q: DOES THE LIFT HAVE TO GO ALL THE WAY UP?

- A: YES - in order for your lift to function as intended the lift must ALWAYS be stored in the full upright position when the boat is unattended.

## Q: IS MY BOAT SECURE?

- A: Yes, once you verify that the lift is Over-Center™, switch off the power and lock the power unit box, there is less chance of theft.

## Q: DO I NEED A MOORING LINE?

- A: Under most circumstances one mooring line is sufficient to prevent the boat from drifting away if the lift inadvertently lowers or the water level rises.

## Q: HOW MUCH SUN DOES THE SOLAR PANEL NEED?

- A: The panel should receive constant sun for at least 8 hours a day.

## Q: HOW DO I CHANGE THE HYDRAULIC FLUID?

- A: The hydraulic fluid should not require replacement for a considerable amount of time. If yours has been contaminated or the hydraulic power unit has been replaced, contact NuCraft for detailed instructions.

## Q: IS THE HYDRAULIC FLUID SAFE FOR THE FISH?

- A: We use a special low-toxicity hydraulic fluid that is safe for the environment. This oil is different than food-grade oil. Only use NuCraft approved fluid in your hydraulic system.

## Q: WHAT IF I GET A NEW BOAT?

- A: Re-leveling the boat lift may be necessary. A new lift will be required if the boat exceeds the weight capacity of your current lift.

## FOR ASSISTANCE OR SERVICE:

Contact your local dealer or call

(989) 275-8054

[www.craftlander.com](http://www.craftlander.com)

To locate a dealer: [sales@nucraftonline.com](mailto:sales@nucraftonline.com)

# YOUR CRAFTLANDER HOIST LIMITED WARRANTIES

During the terms of the Limited Warranties on your aluminum Craftlander hoist, NuCraft Metal Products, Inc. (hereafter referred to as "NuCraft") covers the cost of all parts and labor needed to repair or replace any NuCraft supplied item that proves defective in material, workmanship or factory preparation. These repairs or replacements (parts and labor) will be made by your dealer at no charge using new or remanufactured parts.

## Your Legal Rights Under NuCraft's Limited Warranties

All of the NuCraft Limited Warranties stated in this booklet are the only express written warranties made by NuCraft applicable to the aluminum Craftlander hoist. These Limited Warranties give you specific legal rights and you may also have other rights which vary from state to state. You may have some implied warranties, depending on the state in which your aluminum hoist is registered.

For example, you may have:

1. An "implied warranty of fitness for a particular purpose," (that your hoist is reasonably fit for the general purpose for which it was sold);
2. An "implied warranty of fitness for a particular purpose," (that your hoist is suitable for your special purposes; if your special purposes were specifically disclosed to NuCraft itself-not merely to the distributor or dealer-prior to purchase.)

These implied warranties are limited, to the extent allowed by law, to the time period covered by the written warranties set forth in this publication. Some states do not allow limitations on how long an implied warranty lasts, so the above limitations may not apply to you.

### SUBSEQUENT BUYER/OWNER:

This Warranty is extended only to the first buyer/owner of the hoist. This is defined as the first legal owner of a NuCraft aluminum Craftlander other than an authorized Distributor or Dealer who has bought the hoist from NuCraft for resale to the public.

### HOIST ALTERATION:

This warranty does not cover alteration of the aluminum Craftlander hoist, or failure of hoist components caused by such alteration.

### PRODUCTION CHANGES:

NuCraft and its distributors/dealers reserve the right to make changes in aluminum Craftlander hoists built and/or sold by them at any time without incurring any obligation to make the same or similar changes on hoists previously built and/or sold by them.

## Your 2-Year Basic Limited Warranty

### WHAT IS COVERED:

The 2-Year "Basic Warranty" covers every NuCraft supplied part on your aluminum Craftlander hoist and aluminum canopy support frame.

The "Basic Warranty" begins on your hoist's Warranty Start Date. The Warranty Start Date is the earlier of (1) the date you take delivery of your new aluminum Craftlander hoist, OR (2) the date the hoist was first put into service (for example, as a dealer "demo" or as a NuCraft company hoist). The "Basic Warranty" lasts for 2 years (24 months) from this date.

The "Basic Warranty" covers the cost of all parts and labor needed to repair any item on your aluminum Craftlander hoist that is defective in material, workmanship or factory preparation. You pay nothing for these repairs.

## Your 15-Year Fabricated Frame & Extrusion Warranty

### WHAT IS COVERED:

The "Frame and Extrusion Warranty" covers these parts and components of your aluminum Craftlander hoist frame for 15 years counted from your hoist's Warranty Start Date:

Extruded Aluminum: columns, rails, spreaders, crossmembers, "Twin Beams", legs, stands, extensions, canopy inserts, bows, rails, and clamps.

Fabricated: hoist wheel, winch, corner brackets, column guide plates, and footpads.

## What your NuCraft Limited Warranties Do Not Cover

Vinyl canopy covers are covered by a 5-Year Limited Warranty by the material manufacturer.

Your NuCraft Limited Warranties do not cover the costs of repairing damage caused by environmental factors or acts of God. "Environmental factors" include such things as airborne fallout, chemicals, tree sap, salt, ocean spray, and water hazards. "Acts of God" include such things as hailstorms, windstorms, tornadoes, sandstorms, lightning, floods and earthquakes.

Your NuCraft Limited Warranties do not cover the costs of repairing damage caused by poor or improper maintenance.

Your NuCraft Limited Warranties do not cover the costs of normal/scheduled maintenance of your aluminum Craftlander hoist. They do not cover the cost of lubrication, replacing cables or fasteners unless done as the result of repair covered by your 2-year "Basic Warranty".

Your NuCraft Limited Warranties do not cover the costs of repairing damage or conditions caused by fire or accident; by abuse or negligence; by misuse; by tampering with parts; by improper adjustment or alteration; or by any changes made to your aluminum Craftlander hoist; the cost of rental hoist or slip; gasoline, telephone, travel or lodging; the loss of personal or commercial property; the loss of revenue, etc.

NOTE: Some states do not allow the exclusion or limitation of incidental or consequential damages, so the above limitations or exclusions may not apply to you.

## How To Get Warranty Service for Your Hoist

Please contact the dealer from whom you bought the hoist for warranty service. When contacting your dealer, please provide them with your hoist's model number, hoist serial number, date of purchase and the nature of the problem. If contact with the dealer is not feasible, please contact NuCraft Metal Products for further assistance.

*Proudly Made in Michigan By: NuCraft Metal Products 402 Southline Rd. Roscommon, MI 48653*